

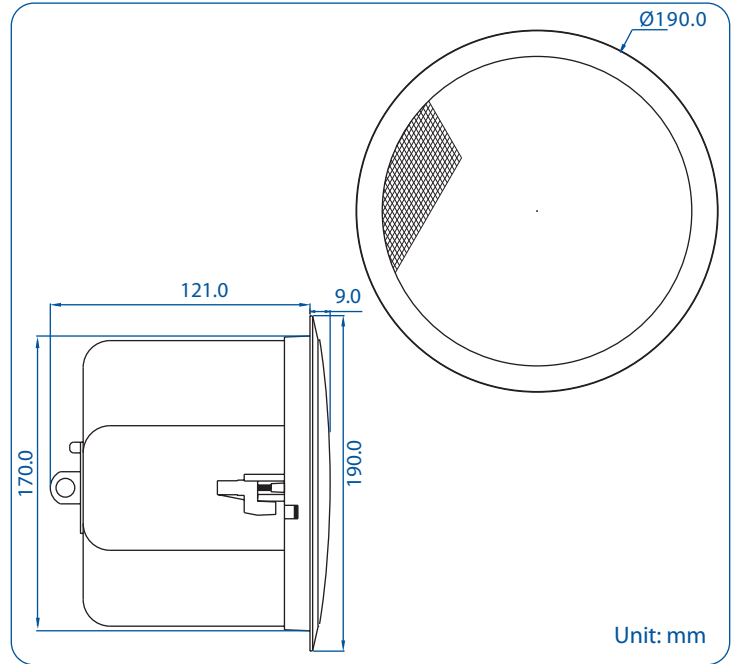

CSB-3 Series Bass Reflex 2-Way Ceiling Loudspeaker



- 100 Hours Life Tested
- CE Certified (EMC & LVD)
- IP Rated
- Rustproof
- UL94V0
- BS 5839 Part 8
- EASE Data
- RoHS Compliance
- UV Protected
- Withstanding/Insulation Tested

- Compact foreground and sound reinforcement quality.
- Ported enclosure for extended bass response.
- Very high quality 2-way speaker system with 3.5" polypropylene bass/mid cone & 8-ounce magnet + 0.5" mylar laminate dome tweeter.
- 15 watt transformer with multi tapplings down to 1.9W (100V) & 1W (70V).
- Discreet rotary power selector.
- Optional powerful 8Ω version.
- Fully rated for air handling spaces.
- Removable locking connector with screw-down terminals. 2 input terminals and 2 loop-thru output terminals.
- Dished grille design for acoustic integrity.
- Finished in brilliant white (RAL 9016).

Model No.	CSB-3150	CSB-3308
Rated Power (rms)	15W	30W
Impedance	667Ω, 1.33kΩ, 2.67kΩ & 5.33kΩ	8Ω
Power Taps @ 100V	15W, 7.5W, 3.75W, 1.9W & 8Ω	N. A.
Power Taps @ 70V	7.5W, 3.75W, 1.9W, 1W & 8Ω	
SPL (1W / 1M)	86dB	
Max. SPL (Rated W / 1M)	98dB	101dB
Frequency Range (-10dB)	85Hz ~ 25KHz	
Dispersion 1K Hz / 4K Hz	210° / 140°	
Ambient Temperature	-20°C ~ +60°C	
Power Selection	Selecting Switch	N. A.
Termination	Removable locking connector with screw-down terminals. 2 input terminals and 2 loop-thru output terminals.	
Material	Baffle: High impact ABS, Backcan: Steel	
Colour / Finish	White (RAL 9016)	
Dimensions	190.0 (7.48) Dia. X 130.0 (5.12) Height mm. (in.)	
Cutout Size	170.0 (6.69) Dia. mm. (in.)	
Net Weight (ea)	1.63 kgs (3.59 lbs)	1.36 kgs (2.99 lbs.)
Mounting	Rotating Mount Tabs	