

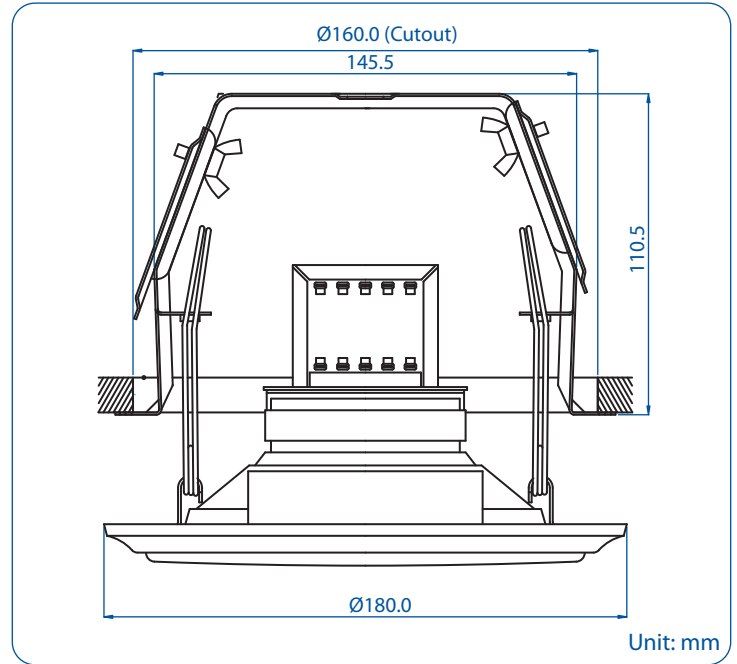

QCM-5061

Quick-Mount Ceiling Loudspeaker



- 100 Hours Life Tested
- CE Certified (EMC & LVD)
- IP Rated
- Rustproof
- UL94V0
- BS 5839 Part 8
- EASE Data
- RoHS Compliance
- UV Protected
- Withstanding/Insulation Tested

- Shares generic low profile grille design & simple fit system throughout entire QCM series.
- Fitted with a 5.25" twin cone driver unit. Designed to offer wide response for music & speech.
- 6 watt transformer with multi tapplings down to 0.75W (100V) & 0.375W (70V).
- Built-in ceiling tile cutout marker.
- Dished grille design for acoustic integrity.
- Galvanized steel construction, finished in brilliant white (RAL 9003).

Model No.	QCM-5061
Rated Power (rms)	6W
Impedance	1.67kΩ, 3.33kΩ, 6.67kΩ & 13.33kΩ
Power Taps @ 100V	6W, 3W, 1.5W & 0.75W
Power Taps @ 70V	3W, 1.5W, 0.75W & 0.375W
SPL (1W / 1M)	92dB
Max. SPL (Rated W / 1M)	99dB
Frequency Range (-10dB)	100Hz ~ 20KHz
Dispersion 1K Hz / 4K Hz	140° / 70°
Ambient Temperature	-30°C ~ +60°C
Power Selection	Plug
Material	Baffle: Steel, Grille: Steel
Colour / Finish	White (RAL 9003)
Dimensions	180.0 (7.09) Dia. X 114.0 (4.50) Height mm. (in.)
Cutout Size	160.0 (6.30) Dia. mm. (in.)
Net Weight (ea)	1.30 kgs (2.87 lbs)
Mounting	Spring loaded Quick-Mount Bracket Assembly