

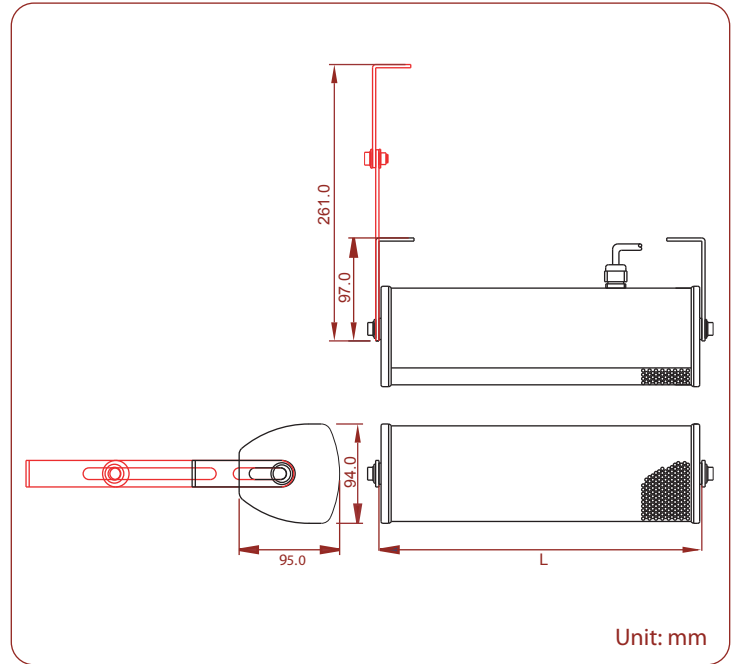

CLS-3 Voice Alarm Series "Contractor Series" Column Loudspeaker



- 100 Hours Life Tested
- CE Certified (EMC & LVD)
- IP Rated
- Rustproof
- UL94V0
- BS 5839 Part 8
- EASE Data
- RoHS Compliance
- UV Protected
- Withstanding/Insulation Tested

- Compliant to BS5839 part 8 (British standard for voice alarm system).
- Highly cost effective solution.
- Durable galvanize steel housing. Attractive slimline construction.
- Fitted with high specification driver units / tweeter for exceptional speech & music reproduction.
- Suitable for accurate, "long throw" applications.
- Available in 10 - 20 - 30 & 40 watt options.
- Multi 100 & 70 volt line.
- Mounting bracket included.
- Available in White (RAL 9003).

Model No.	CLS-3100VA	CLS-3200VA	CLS-3300VA	CLS-3400VA
Rated Power (rms)	10W	20W	30W	40W
Number of Loudspeakers	3" Woofer X 1 + 2" Tweeter X 1	3" Woofer X 2 + 2" Tweeter X 1	3" Woofer X 3 + 2" Tweeter X 1	3" Woofer X 4 + 2" Tweeter X 1
Impedance	1kΩ, 2kΩ, 4kΩ & 8kΩ	500Ω, 1kΩ, 2kΩ & 4kΩ	333Ω, 667Ω, 1.33kΩ & 2.67kΩ	250Ω, 500Ω, 1kΩ & 2kΩ
Power Taps @ 100V	10W, 5W, 2.5W & 1.25W	20W, 10W, 5W & 2.5W	30W, 15W, 7.5W & 3.75W	40W, 20W, 10W & 5W
Power Taps @ 70V	5W, 2.5W, 1.25W & 0.625W	10W, 5W, 2.5W & 1.25W	15W, 7.5W, 3.75W & 1.9W	20W, 10W, 5W & 2.5W
SPL (1W / 1M)	85dB	87dB	88dB	90dB
Max. SPL (Rated W / 1M)	95dB	100dB	103dB	106dB
Frequency Range (-10dB)	170Hz ~ 20KHz	150Hz ~ 20KHz	140Hz ~ 20KHz	140Hz ~ 20KHz
Dispersion 1K Hz / 4K Hz	H: 190° / 160°, V: 150° / 85°	H: 190° / 120°, V: 125° / 30°	H: 195° / 105°, V: 105° / 30°	H: 205° / 140°, V: 85° / 45°
Ambient Temperature	-20°C ~ +60°C			
Material	Housing: Galvanized Steel, Grille: Steel			
Colour / Finish	White (RAL 9003)			
Dimensions	222.0 (8.74) L X 94.0 (3.70) W X 95.0 (3.74) D mm. (in.)	304.0 (11.97) L X 94.0 (3.70) W X 95.0 (3.74) D mm. (in.)	387.0 (15.24) L X 94.0 (3.70) W X 95.0 (3.74) D mm. (in.)	469.0 (18.46) L X 94.0 (3.70) W X 95.0 (3.74) D mm. (in.)
Net Weight (ea)	1.31 kgs (2.89 lbs)	1.81 kgs (3.99 lbs)	2.30 kgs (5.07 lbs)	2.80 kgs (6.17 lbs)
Mounting	L Type Steel Bracket			