

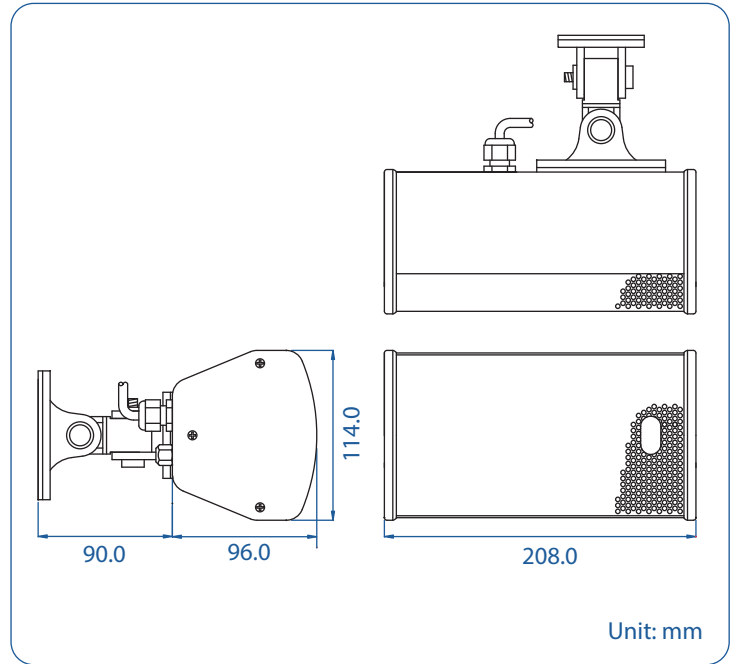

CAE-3150

Waterproof Cabinet Loudspeaker



- 100 Hours Life Tested
- CE Certified (EMC & LVD)
- IP Rated
- Rustproof
- UL94V0
- BS 5839 Part 8
- EASE Data
- RoHS Compliance
- UV Stable
- Withstanding/Insulation Tested

- Ingress protected to IEC 529 IP 66, suitable for indoor and outdoor use
- Durable Nylon / Fibre multi bracket included (broken tested up to 45.4 kg)
- High quality 2 way system suitable for music & speech
- Rotary power selector
- Attractive slimline construction
- Durable extruded aluminium housing
- Finished in white

Model No.	CAE-3150
Rated Power (rms)	15W
Impedance	333Ω, 667Ω, 1.33kΩ, 2.67kΩ, OFF & 8Ω
Power Taps @ 100V	15W, 7.5W, 3.75W, OFF & 8Ω
Power Taps @ 70V	15W, 7.5W, 3.75W, 1.9W, OFF & 8Ω
SPL (1W / 1m)	88dB
Max. SPL (Rated W / 1m)	100dB
Frequency Range (-10dB)	130 Hz ~ 20k Hz
Dispersion 1k Hz / 4k Hz	190° / 100°
Operating Temperature	-30°C ~ +60°C
Ingress Protection	IEC 529 IP 66
Power Selection	Selecting switch
Material	Housing: Extruded aluminium, Grille: Aluminium
Colour / Finish	White
Dimensions	208.0 (8.19) L X 114.0 (4.49) W X 96.0 (3.78) D mm. (in.)
Net Weight (ea)	2.10 kg (4.63 lb.)
Mounting	Multi bracket (B8-19-0091)