

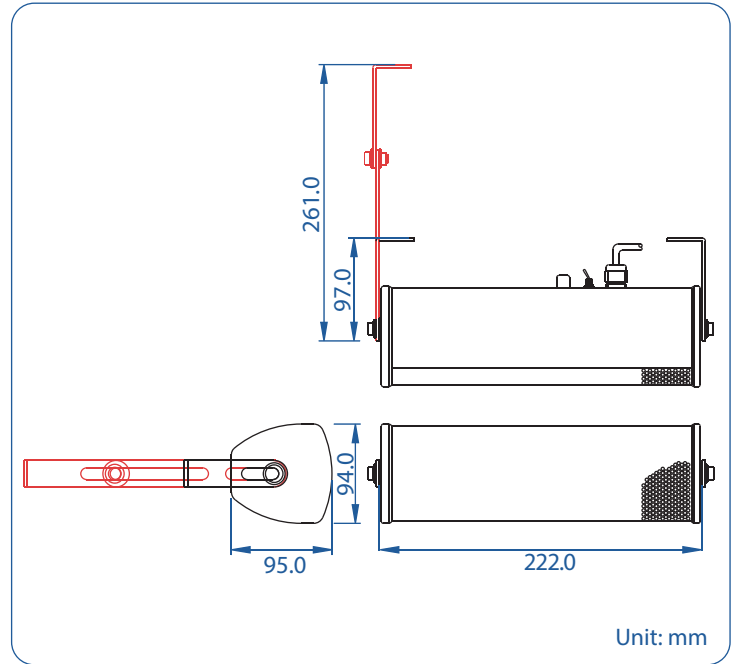

CLS-3200 "Contractor Series" Column Loudspeaker



- 100 Hours Life Tested
- CE Certified (EMC & LVD)
- IP Rated
- Rustproof
- UL94V0
- BS 5839 Part 8
- EASE Data
- RoHS Compliance
- UV Stable
- Withstanding/Insulation Tested

- Rotary power selector
- Rear-mounted low-cut switch for speech
- Attractive slimline construction
- Fitted with high specification driver units / tweeter for exceptional speech & music reproduction
- Suitable for accurate, "long throw" applications
- Available in 20 watt
- Highly cost effective solution
- Durable galvanize steel housing
- Mounting bracket included
- Finished in white

Model No.	CLS-3200
Rated Power (rms)	20W
Number of Loudspeakers	3" Woofer X 2 + 2" Tweeter X 1
Impedance	250Ω, 500Ω, 1kΩ, 2kΩ & 4kΩ
Power Taps @ 100V	20W, 10W, 5W & 2.5W
Power Taps @ 70V	20W, 10W, 5W, 2.5W & 1.25W
SPL (1W / 1m)	87dB
Max. SPL (Rated W / 1m)	100dB
Frequency Range (-10dB)	150 Hz ~ 20k Hz
Dispersion 1k Hz / 4k Hz	H: 190° / 120°, V: 125° / 30°
Operating Temperature	-30°C ~ +60°C
Low-cut Switch	400 Hz
Power Selection	Selecting switch
Material	Housing: Galvanized steel, Grille: Steel
Colour / Finish	White
Dimensions	304.0 (11.97) L X 94.0 (3.70) W X 95.0 (3.74) D mm. (in.)
Net Weight (ea)	1.81 kg (3.99 lb.)
Mounting	L Type steel bracket