

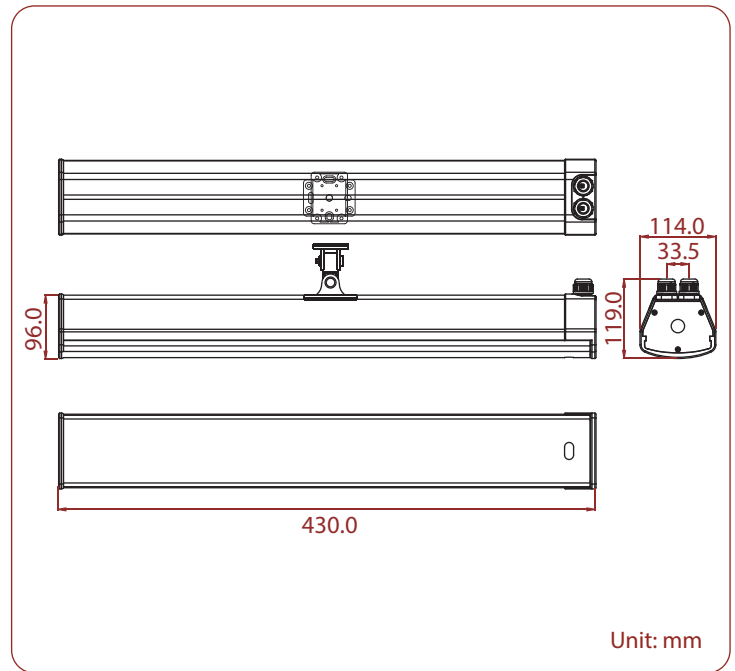

# COS-3100VA

## Waterproof Column Loudspeaker

【Voice Alarm】



Unit: mm

- ✓ 100 Hours Life Tested
- ✓ CE Certified (EMC & LVD)
- ✓ IP Rated
- ✓ RoHS Compliance
- ✓ UL94V0
- ✓ BS 5839 Part 8 & EN 60849
- ✓ EASE Data
- ✓ Multi-Bracket Broken Tested
- ✓ Rustproof
- ✓ Withstanding/Insulation Tested

- Compliant with British Standard BS 5839 part 8 and EN 60849
- Rotary power selector
- Two cable entries to enable loop in loop out installation
- Ingress protected to IEC 60529 IP 66, suitable for indoor and outdoor use
- Durable extruded aluminium housing
- Durable aluminium alloy multi bracket broken tested up to 1500 kgf
- Finished in white

Model No.	COS-3100VA
Rated Power (rms)	10W
Number of Loudspeakers	3.5" Woofer X 2 + 3.25" Tweeter X 1
Impedance	500Ω, 1kΩ, 2kΩ, 4kΩ & 8kΩ
Power Taps @ 100V	10W, 5W, 2.5W & 1.25W
Power Taps @ 70V	10W, 5W, 2.5W, 1.25W & 0.625W
SPL (1W / 1m)	91dB
Max. SPL (Rated W / 1m)	101dB
Frequency Range (-10dB)	130 Hz ~ 20k Hz
Dispersion 1k Hz / 4k Hz	H: 180°/ 100°, V: 75°/ 30°
Operating Temperature	-30°C ~ +60°C
Ingress Protection	IEC 60529 IP 66
Power Selection	Selecting Switch
Material	Housing: Extruded aluminium, Grille: Aluminium
Colour / Finish	White
Dimensions	430.0 (16.92) L X 114.0 (4.49) W X 96.0 (3.78) D mm. (in.)
Net Weight (ea)	3.10 kg (6.82 lb.)
Mounting	Aluminium alloy multi bracket