

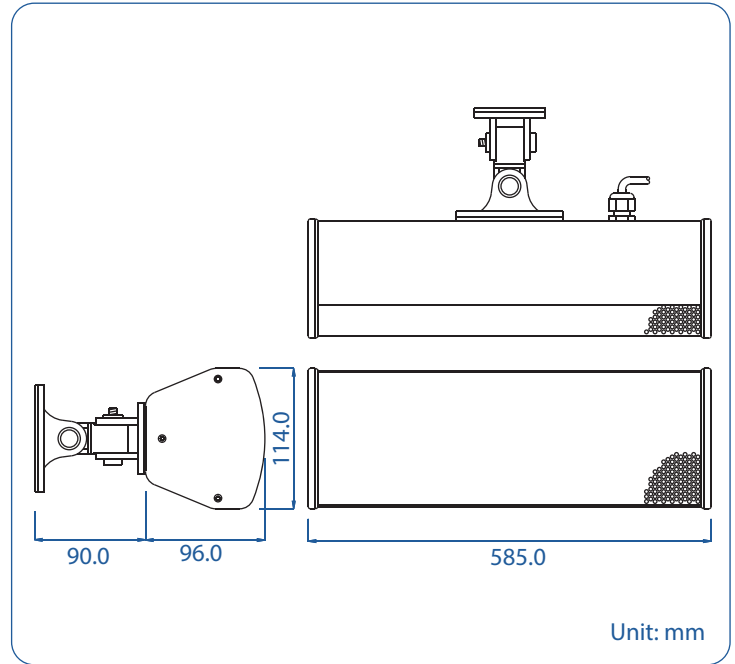

COS-3200

Waterproof Column Loudspeaker



Unit: mm

- 100 Hours Life Tested
- CE Certified (EMC & LVD)
- IP Rated
- RoHS Compliance
- UL94V0
- BS 5839 Part 8
- EASE Data
- Multi-Bracket Broken Tested
- Rustproof
- Withstanding/Insulation Tested

- **Ingress protected to IEC 529 IP 66, suitable for indoor and outdoor use**
- **Durable aluminium alloy multi bracket broken tested up to 1500 kgf**
- Fitted with high specification driver units / tweeter for exceptional speech & music reproduction
- Suitable for accurate, "long throw" applications
- Durable extruded aluminium housing
- Attractive slimline construction
- Available in 20 watt
- Finished in white

Model No.	COS-3200
Rated Power (rms)	20W
Number of Loudspeakers	3.5" Woofer X 4 + 3.25" Tweeter X 1
Impedance	250Ω, 500Ω, 1kΩ, 2kΩ & 4kΩ
Power Taps @ 100V	20W, 10W, 5W & 2.5W
Power Taps @ 70V	20W, 10W, 5W, 2.5W & 1.25W
SPL (1W / 1m)	92dB
Max. SPL (Rated W / 1m)	105dB
Frequency Range (-10dB)	120 Hz ~ 20k Hz
Dispersion 1k Hz / 4k Hz	H : 180°/ 90°, V : 45° / 20°
Operating Temperature	-40°C ~ +60°C
Ingress Protection	IEC 529 IP66
Power Selection	6 - core cable
Material	Housing: Extruded aluminium, Grille: Aluminium
Colour / Finish	White
Dimensions	585.0 (23.03) L X 114.0 (4.49) W X 96.0 (3.78) D mm. (in.)
Net Weight (ea)	4.00 kg (8.82 lb.)
Mounting	Aluminium alloy multi bracket