

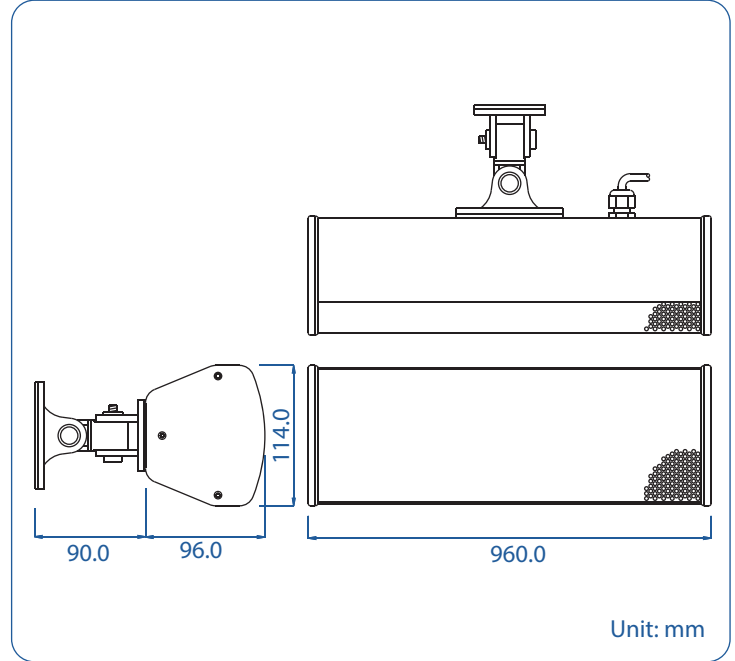

COS-3400

Waterproof Column Loudspeaker



Unit: mm

- 100 Hours Life Tested
- CE Certified (EMC & LVD)
- IP Rated
- RoHS Compliance
- UL94V0
- BS 5839 Part 8
- EASE Data
- Multi-Bracket Broken Tested
- Rustproof
- Withstanding/Insulation Tested

- **Ingress protected to IEC 529 IP 66, suitable for indoor and outdoor use**
- **Durable aluminium alloy multi bracket broken tested up to 1500 kgf**
- Fitted with high specification driver units / tweeter for exceptional speech & music reproduction
- Suitable for accurate, "long throw" applications
- Durable extruded aluminium housing
- Attractive slimline construction
- Available in 40 watt
- Finished in white

Model No.	COS-3400
Rated Power (rms)	40W
Number of Loudspeakers	3.5" Woofer X 8 + 3.25" Tweeter X 1
Impedance	125Ω, 250Ω, 500Ω, 1kΩ & 2kΩ
Power Taps @ 100V	40W, 20W, 10W & 5W
Power Taps @ 70V	40W, 20W, 10W, 5W & 2.5W
SPL (1W / 1m)	93dB
Max. SPL (Rated W / 1m)	109dB
Frequency Range (-10dB)	110 Hz ~ 20k Hz
Dispersion 1k Hz / 4k Hz	H : 180° / 90°, V : 30° / 20°
Operating Temperature	-40°C ~ +60°C
Ingress Protection	IEC 529 IP66
Power Selection	6 - core cable
Material	Housing: Extruded aluminium, Grille: Aluminium
Colour / Finish	White
Dimensions	960.0 (37.80) L X 114.0 (4.49) W X 96.0 (3.78) D mm. (in.)
Net Weight (ea)	7.70 kg (16.98 lb.)
Mounting	Aluminium alloy multi bracket