

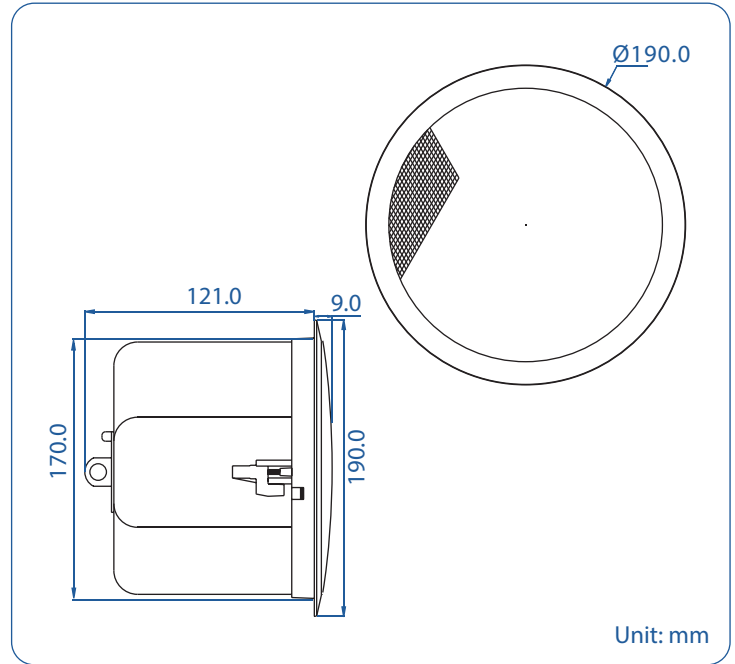

# CSB-3150

## Bass Reflex 2-Way Ceiling Loudspeaker



- 100 Hours Life Tested
- CE Certified (EMC & LVD)
- IP Rated
- Rustproof
- UL94V0
- BS 5839 Part 8
- EASE Data
- RoHS Compliance
- UV Stable
- Withstanding/Insulation Tested

- Very high quality 2-way speaker system with 3.5" polypropylene bass/mid cone & 8-ounce magnet + 0.5" mylar laminate dome tweeter
- Rotary power selector
- Fully rated for air handling spaces
- Bass reflex design
- Compact foreground and sound reinforcement quality
- Ported enclosure for extended bass response
- Removable locking connector with screw-down terminals, 2 input terminals and 2 loop-thru output terminals
- Dished grille design for acoustic integrity
- Finished in white

Model No.	CSB-3150
Rated Power (rms)	15W
Impedance	667Ω, 1.33kΩ, 2.67kΩ, 5.33kΩ & 8Ω
Power Taps @ 100V	15W, 7.5W, 3.75W, 1.9W & 8Ω
Power Taps @ 70V	7.5W, 3.75W, 1.9W, 1W & 8Ω
SPL (1W / 1m)	86dB
Max. SPL (Rated W / 1m)	98dB
Frequency Range (-10dB)	85 Hz ~ 25k Hz
Dispersion 1k Hz / 4k Hz	210° / 140°
Operating Temperature	-30°C ~ +60°C
Power Selection	Selecting switch
Termination	Removable locking connector with screw-down terminals, 2 input terminals and 2 loop-thru output terminals
Material	Baffle: High impact ABS, Backcan: Steel
Colour / Finish	White
Dimensions	190.0 (7.48) Dia. X 130.0 (5.12) Height mm. (in.)
Cutout Size	170.0 (6.69) Dia. mm. (in.)
Net Weight (ea)	1.63 kg (3.59 lb.)
Mounting	Rotating mount tabs