

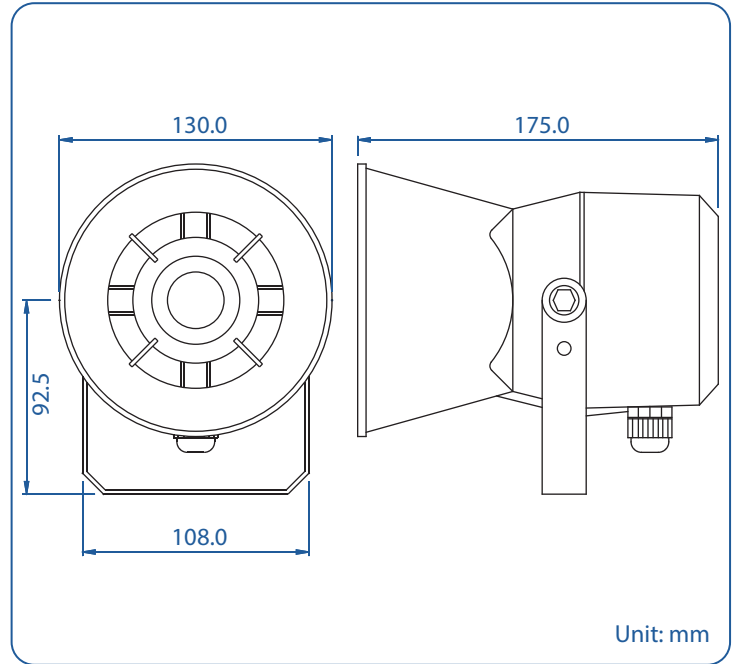

MPH-5300

Compact Power-Horn Loudspeaker



- 100 Hours Life Tested
- CE Certified (EMC & LVD)
- IP Rated
- Rustproof
- UL94V0
- BS 5839 Part 8
- EASE Data
- RoHS Compliance
- UV Stable
- Withstanding/Insulation Tested

- High impact ABS cabinet, UV stable
- Ingress protected to IEC 529 IP 67
- Stainless steel mounting bracket & exterior hardware
- Very high efficiency
- High power 30 watt rms
- 6-core multi-tapping glanded cable
- Finished in white

Model No.	MPH-5300
Rated Power (rms)	30W
Impedance	167Ω, 333Ω, 667Ω, 1.33kΩ & 2.67kΩ
Power Taps @ 100V	30W, 15W, 7.5W & 3.75W
Power Taps @ 70V	30W, 15W, 7.5W, 3.75W & 1.9W
SPL (1W / 1m)	106dB
Max. SPL (Rated W / 1m)	121dB
Frequency Range (-10dB)	500 Hz ~ 7k Hz
Frequency Range (-20dB)	430 Hz ~ 16k Hz
Dispersion 1k Hz / 4k Hz	240° / 45°
Operating Temperature	-30°C ~ +60°C
Ingress Protection	IEC 529 IP 67
Power Selection	6-core cable
Material	Housing: High impact ABS with UV stable
Colour / Finish	White
UV Stable	Available
Dimensions	130.0 (5.12) Dia. X 175.0 (6.89) Length mm. (in.)
Net Weight (ea)	1.70 kg (3.75 lb.)
Mounting	U Type stainless steel bracket