

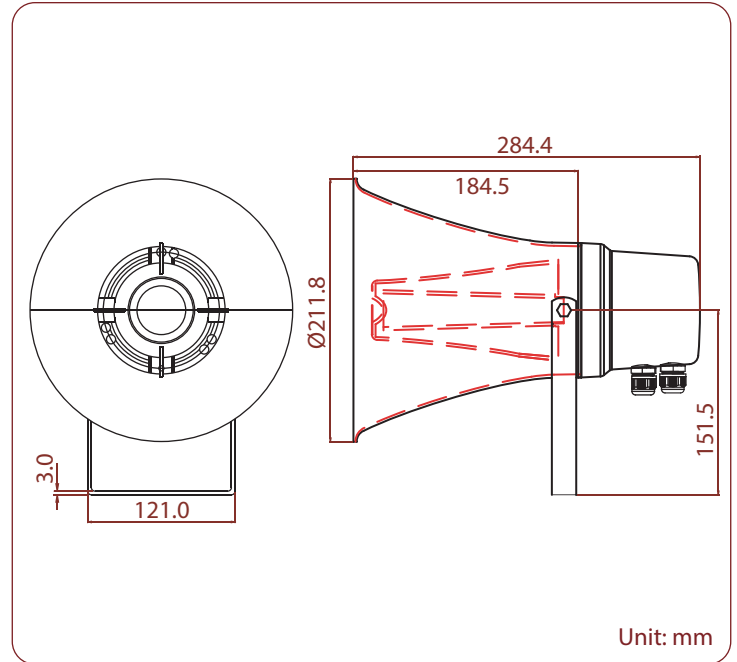

PRH-8151/8VA Plastic Horn Loudspeaker

【Voice Alarm】



- 100 Hours Life Tested
- CE Certified (EMC & LVD)
- IP Rated
- Rustproof
- UL94V0
- BS 5839 Part 8 & EN 60849
- EASE Data
- RoHS Compliance
- UV Stable
- Withstanding/Insulation Tested

- Compliant with British Standard BS 5839 part 8 and EN 60849
- Ingress protected to IEC 529 IP 66
- Two cable entries to enable loop in loop out installation
- Stainless steel mounting bracket & exterior hardware
- High impact ABS construction
- Very high efficiency
- Finished in grey

Model No.	PRH-8151/8VA
Rated Power (rms)	15W
Impedance	667Ω, 1.33kΩ, 2.67kΩ & 5.33kΩ
Power Taps @ 100V	15W, 7.5W, 3.75W & 1.87W
Power Taps @ 70V	7.5W, 3.75W, 1.87W & 0.94W
SPL (1W / 1m)	108dB
Max. SPL (Rated W / 1m)	120dB
Frequency Range (-10dB)	460 Hz ~ 9k Hz
Frequency Range (-20dB)	300 Hz ~ 11k Hz
Dispersion 1k Hz / 4k Hz	120° / 30°
Operating Temperature	-30°C ~ +60°C
Ingress Protection	IEC 529 IP 66
Power Selection	Plug
Material	Housing: UL94V0 high impact ABS
Colour / Finish	Grey
Dimensions	211.8 (8.33) Dia. X 284.4 (11.20) Length mm. (in.)
Net Weight (ea)	1.75 kg (3.85 lb.)
Mounting	U Type stainless steel bracket