

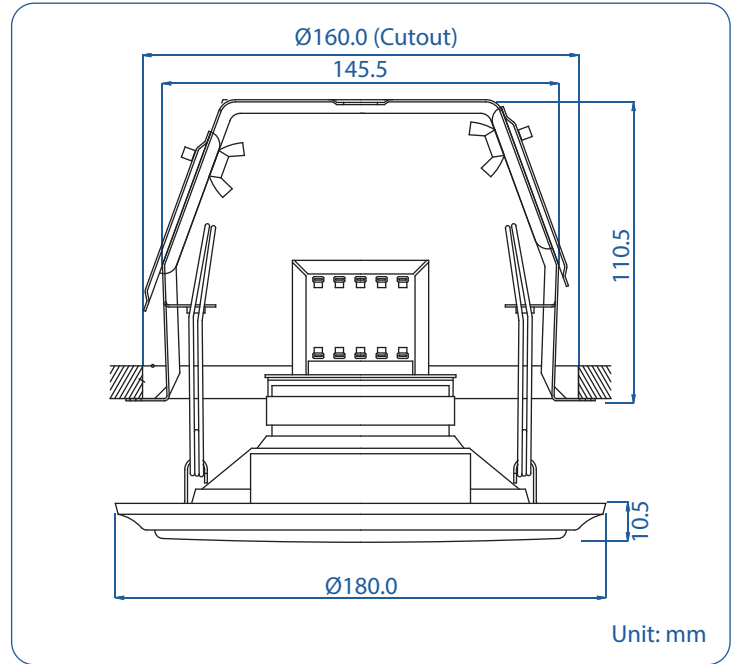

QCM-5061

Quick-Mount Ceiling Loudspeaker



- 100 Hours Life Tested
- CE Certified (EMC & LVD)
- IP Rated
- Rustproof
- UL94V0
- BS 5839 Part 8
- EASE Data
- RoHS Compliance
- UV Stable
- Withstanding/Insulation Tested

- Fitted with a 5.25" twin cone driver unit
- Designed to offer wide response for music & speech
- Dished grille design for acoustic integrity
- Finished in white

Model No.	QCM-5061
Rated Power (rms)	6W
Impedance	1.67kΩ, 3.33kΩ, 6.67kΩ & 13.33kΩ
Power Taps @ 100V	6W, 3W, 1.5W & 0.75W
Power Taps @ 70V	3W, 1.5W, 0.75W & 0.375W
SPL (1W / 1m)	92dB
Max. SPL (Rated W / 1m)	99dB
Frequency Range (-10dB)	100 Hz ~ 20k Hz
Dispersion 1k Hz / 4k Hz	140° / 70°
Operating Temperature	-30°C ~ +60°C
Power Selection	Plug
Material	Baffle: Steel, Grille: Steel
Colour / Finish	White
Dimensions	180.0 (7.09) Dia. X 121.0(4.76) Height mm. (in.)
Cutout Size	160.0 (6.30) Dia. mm. (in.)
Net Weight (ea)	1.30 kg (2.87 lb.)
Mounting	Spring loaded Quick-Mount bracket assembly