

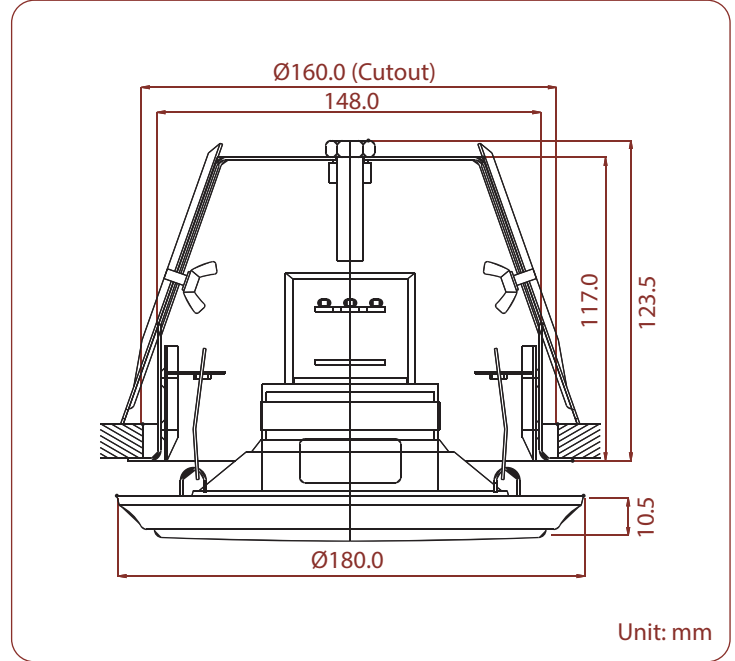

# QCM-5061VAF Quick-Mount Ceiling Loudspeaker



- 100 Hours Life Tested
- CE Certified (EMC & LVD)
- IP Rated
- Rustproof
- UL94V0
- BS 5839 Part 8 & EN 60849
- EASE Data
- RoHS Compliance
- UV Stable
- Withstanding/Insulation Tested

- **Compliant with British Standard BS 5839 part 8 and EN 60849**
- **Twin gland entry steel fire dome with patented "SUPER-FIT" system**
- **Mild steel construction capable of withstanding temperature of 650°C**
- **Ceramic termination blocks and fire resistant internal cabling**
- **150°C thermal isolating fuse**
- **Fitted with a 5.25" twin cone driver unit**
- **Designed to offer wide response for music & speech**
- **Dished grille design for acoustic integrity**
- **Finished in white**

Model No.	QCM-5061VAF
Rated Power (rms)	6W
Impedance	1.67kΩ, 3.33kΩ, 6.67kΩ & 13.33kΩ
Power Taps @ 100V	6W, 3W, 1.5W & 0.75W
Power Taps @ 70V	3W, 1.5W, 0.75W & 0.375W
SPL (1W / 1m)	92dB
Max. SPL (Rated W / 1m)	99dB
Frequency Range (-10dB)	100 Hz ~ 20k Hz
Dispersion 1k Hz / 4k Hz	140° / 70°
Operating Temperature	-30°C ~ +60°C
Power Selection	Plug
Material	Baffle: Steel, Grille: Steel
Colour / Finish	White
Dimensions	180.0 (7.09) Dia. X 134.0 (5.27) Height mm. (in.)
Cutout Size	160.0 (6.30) Dia. mm. (in.)
Net Weight (ea)	1.70 kg (3.74 lb.)
Mounting	Spring loaded Quick-Mount assembly