

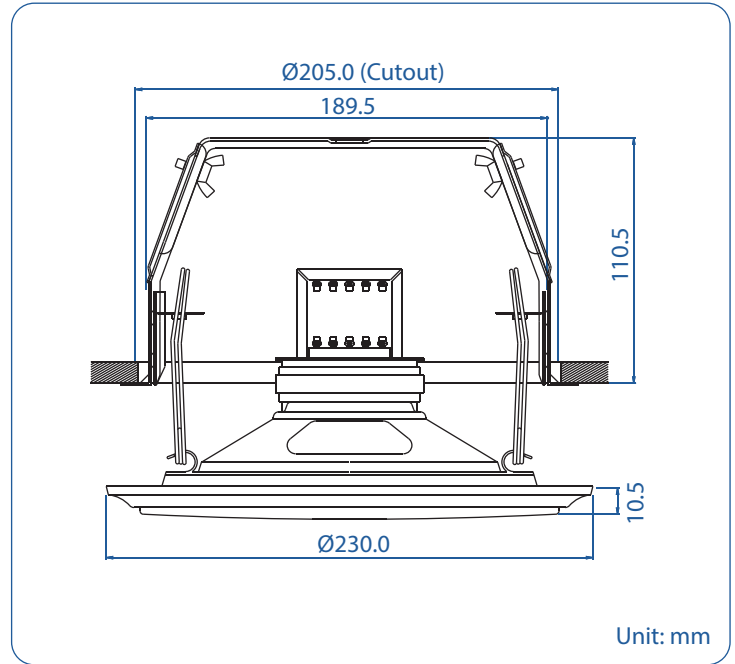

QCM-6081T

Quick-Mount 2-Way Ceiling Loudspeaker



- 100 Hours Life Tested
- CE Certified (EMC & LVD)
- IP Rated
- Rustproof
- UL94V0
- BS 5839 Part 8
- EASE Data
- RoHS Compliance
- UV Stable
- Withstanding/Insulation Tested

- Featuring a high quality 6.5" 2-way speaker, with a paper cone, 10-ounce magnet and 2" tweeter with a bi-polar crossover
- Foreground and sound reinforcement quality
- Dished grille design for acoustic integrity
- Finished in white

Model No.	QCM-6081T
Rated Power (rms)	8W
Impedance	1.25kΩ, 2.50kΩ, 5kΩ & 10kΩ
Power Taps @ 100V	8W, 4W, 2W & 1W
Power Taps @ 70V	4W, 2W, 1W & 0.5W
SPL (1W / 1m)	95dB
Max. SPL (Rated W / 1m)	104dB
Frequency Range (-10dB)	80 Hz ~ 20k Hz
Dispersion 1k Hz / 4k Hz	140° / 65°
Operating Temperature	-30°C ~ +60°C
Power Selection	Plug
Material	Baffle: Steel, Grille: Steel
Colour / Finish	White
Dimensions	230.0 (9.06) Dia. X 1210 (4.76) Height mm. (in.)
Cutout Size	205.0 (8.07) Dia. mm. (in.)
Net Weight (ea)	1.70 kg (3.75 lb.)
Mounting	Spring loaded Quick-Mount bracket assembly