

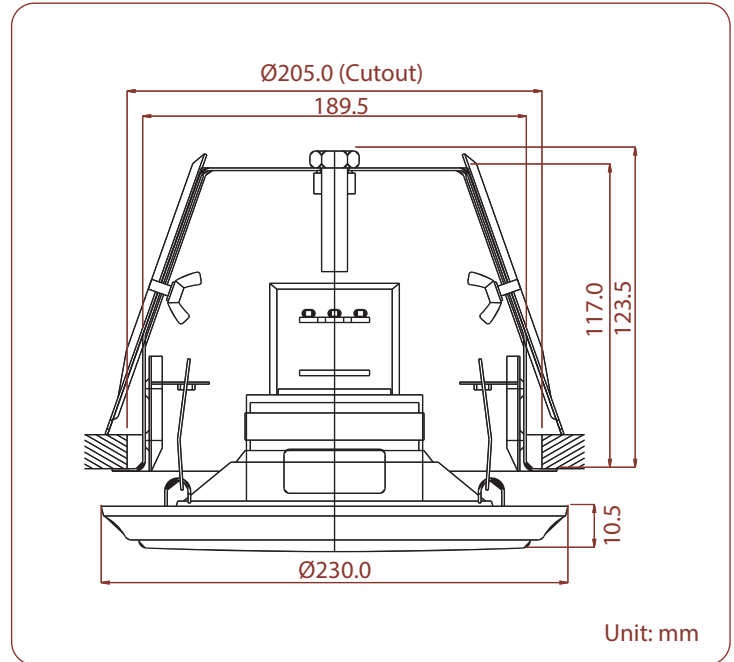

QCM-6081TVAF

Quick-Mount 2-Way Ceiling Loudspeaker



- 100 Hours Life Tested
- CE Certified (EMC & LVD)
- IP Rated
- Rustproof
- UL94V0
- BS 5839 Part 8 & EN 60849
- EASE Data
- RoHS Compliance
- UV Stable
- Withstanding/Insulation Tested

- **Compliant with British Standard BS 5839 part 8 and EN 60849**
- **Twin gland entry steel fire dome with patented "SUPER-FIT" system**
- **Featuring a high quality 6.5" 2-way speaker, with a paper cone, 10-ounce magnet and 2" tweeter with a bi-polar crossover**
- **Mild steel construction capable of withstanding temperature of 650°C**
- **Ceramic termination blocks and fire resistant internal cabling**
- **150°C thermal isolating fuse**
- **Foreground and sound reinforcement quality**
- **Dished grille design for acoustic integrity**
- **Finished in white**

Model No.	QCM-6081TVAF
Rated Power (rms)	8W
Impedance	1.25kΩ, 2.50kΩ, 5kΩ & 10kΩ
Power Taps @ 100V	8W, 4W, 2W & 1W
Power Taps @ 70V	4W, 2W, 1W & 0.5W
SPL (1W / 1m)	95dB
Max. SPL (Rated W / 1m)	104dB
Frequency Range (-10dB)	80 Hz ~ 20k Hz
Dispersion 1k Hz / 4k Hz	140° / 65°
Operating Temperature	-30°C ~ +60°C
Power Selection	Plug
Material	Baffle: Steel, Grille: Steel
Colour / Finish	White
Dimensions	230.0 (9.06) Dia. X 134.0 (5.27) Height mm. (in.)
Cutout Size	205.0 (8.07) Dia. mm. (in.)
Net Weight (ea)	2.30 kg (5.06 lb.)
Mounting	Spring loaded Quick-Mount assembly