

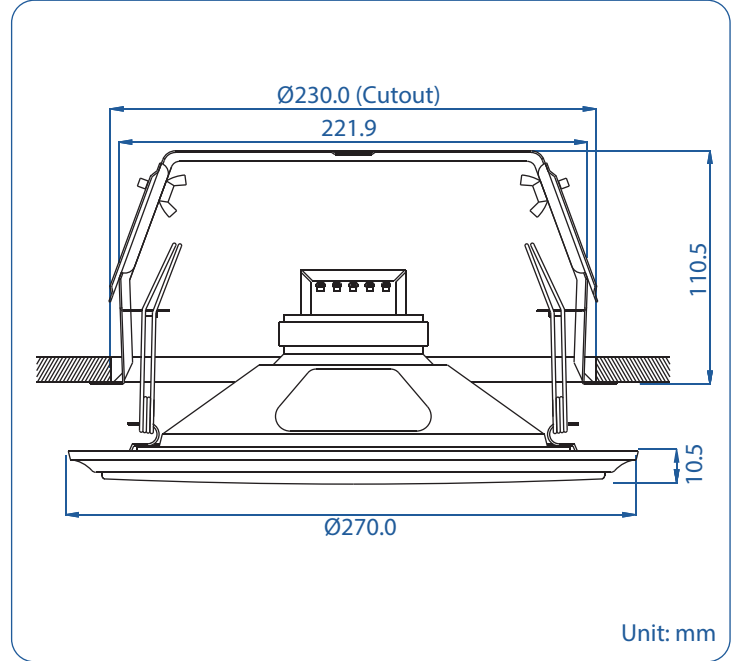

QCM-8101

Quick-Mount Ceiling Loudspeaker



- 100 Hours Life Tested
- CE Certified (EMC & LVD)
- IP Rated
- Rustproof
- UL94V0
- BS 5839 Part 8
- EASE Data
- RoHS Compliance
- UV Stable
- Withstanding/Insulation Tested

- Fitted with an 8" twin cone driver unit
- Designed to offer wide response for music & speech
- Excellent low frequency response
- Dished grille design for acoustic integrity
- Finished in white

Model No.	QCM-8101
Rated Power (rms)	10W
Impedance	1kΩ, 2kΩ, 4kΩ & 8kΩ
Power Taps @ 100V	10W, 5W, 2.5W & 1.25W
Power Taps @ 70V	5W, 2.5W, 1.25W & 0.625W
SPL (1W / 1m)	92dB
Max. SPL (Rated W / 1m)	102dB
Frequency Range (-10dB)	70 Hz ~ 20k Hz
Dispersion 1k Hz / 4k Hz	100° / 45°
Operating Temperature	-30°C ~ +60°C
Power Selection	Plug
Material	Baffle: Steel, Grille: Steel
Colour / Finish	White
Dimensions	270.0 (10.63) Dia. X 121.0 (4.76) Height mm. (in.)
Cutout Size	230.0 (9.06) Dia. mm. (in.)
Net Weight (ea)	1.90 kg (4.19 lb.)
Mounting	Spring loaded Quick-Mount bracket assembly