

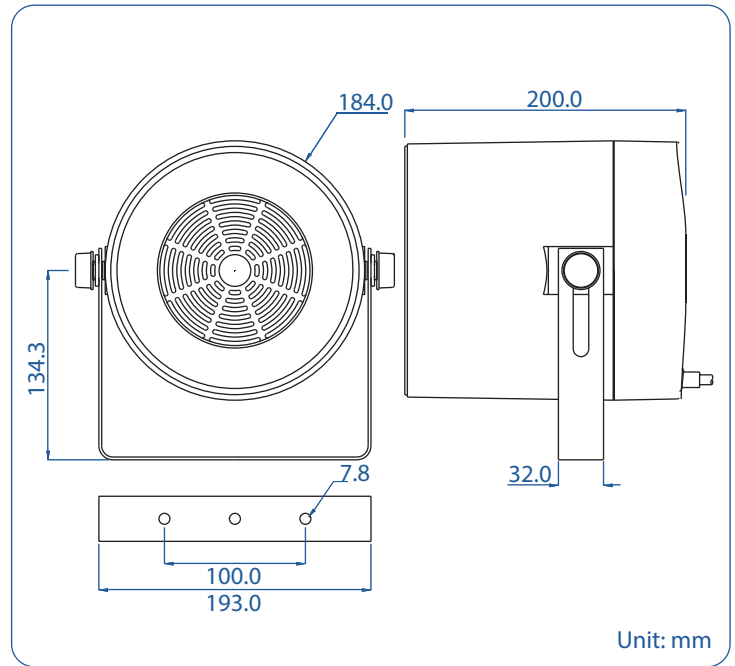

XMR-520PL Sound Projector



- 100 Hours Life Tested
- CE Certified (EMC & LVD)
- IP Rated
- Rustproof
- UL94V0
- BS 5839 Part 8
- EASE Data
- RoHS Compliance
- UV Stable
- Withstanding/Insulation Tested

- **Ingress protected to IEC 529 IP 55**
- **Aluminum bracket, stainless steel exterior hardware**
- **Ideal for music and speech applications**
- **Compact design high impact ABS housing UV stable**
- **Designed to give controlled directional sound characteristics**
- **Finished in ivory**

| Model No. | XMR-520PL |
|--------------------------|--|
| Rated Power (rms) | 20W |
| Impedance | 250Ω, 500Ω, 1kΩ, 2kΩ, 4kΩ & 8Ω |
| Power Taps @ 100V | 20W, 10W, 5W, 2.5W & 8Ω |
| Power Taps @ 70V | 20W, 10W, 5W, 2.5W, 1.25W & 8Ω |
| SPL (1W / 1m) | 98dB |
| Max. SPL (Rated W / 1m) | 111dB |
| Frequency Range (-10dB) | 130 Hz ~ 20k Hz |
| Dispersion 1k Hz / 4k Hz | 130° / 30° |
| Operating Temperature | -30°C ~ +60°C |
| Ingress Protection | IEC 529 IP 55 |
| Power Selection | 7 - core cable |
| Material | Housing: High impact ABS with UV stable |
| Colour / Finish | Ivory |
| Dimensions | 184.0 (7.24) Dia. X 200.0 (7.87) L mm. (in.) |
| Net Weight (ea) | 2.20 kg (4.85 lb.) |
| Mounting | U Type aluminum bracket |