

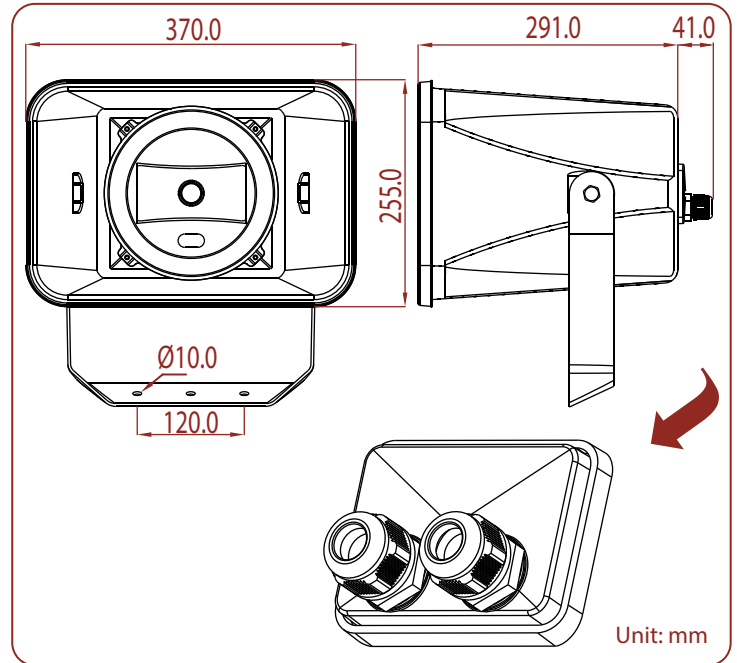

MUH206030 Music Horn Loudspeaker

【 EN54-24 】



Unit: mm

- 100 Hours Life Tested
- CE Certified (EMC & LVD)
- IP Rated
- Rustproof
- UL94V0
- BS 5839 Part 8 & EN 60849
- EASE Data
- RoHS Compliance
- UV Stable
- Withstanding/Insulation Tested

Engineered to provide the highest quality voice and music reproduction for both indoor and outdoor applications where long throw, large area coverage is desired in harsh environments. Ideal for applications such as sports stadiums, cruise liners, school yards, municipal swimming pools, high ambient industrial areas and leisure / theme parks

- **Compliant with EN54-24**
- **Compliant with British Standard BS 5839 part 8 and EN 60849**
- **Two cable entries to enable loop in loop out installation**
- **Available in 30 watt**
- **Ingress protected to IEC 60529 IP 66**
- **Two-way capabilities for security / monitoring applications**
- **UV stable for years of outdoor use**
- **Trunion extruded aluminium bracket with stainless mounting screws**
- **Finished in grey**

Model No.	MUH206030
Rated Power (rms)	30W
Impedance	167Ω, 333Ω, 667Ω, 1.33kΩ & 2.67kΩ
Power Taps @ 100V	30W, 15W, 7.5W & 3.75W
Power Taps @ 70V	30W, 15W, 7.5W, 3.75W & 1.9W
SPL (1W / 1m)	97dB
Sensitivity (1W / 4m) - EN54-24	87dB
Frequency Range (-10dB)	100 Hz ~ 20k Hz
Dispersion 1k Hz / 4k Hz	H : 95° / 75°, V : 90° / 70°
Operating Temperature	-30°C ~ +70°C
Operating Temperature - EN54-24	-20°C ~ +70°C
Ingress Protection	IEC 60529 IP 66
Ingress Protection - EN54-24	IP 33C
Power Selection	Ceramic terminal block
Material	Housing: UL94V0 high impact ABS with UV stable
Colour / Finish	Grey
Dimensions	370.0 (14.57) X 255.0 (10.04) x 291.0 (11.46) Length mm (in.)
Net Weight (ea)	4.60 kg (10.14 lb.)
Mounting	U Type aluminium bracket