

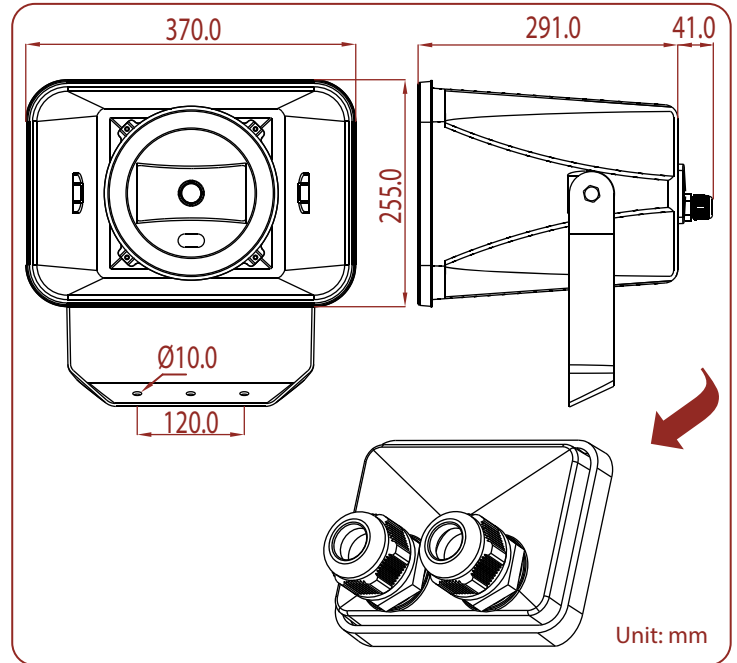

MUH-6600VA Music Horn Loudspeaker

【Voice Alarm】



Unit: mm

- ✓ 100 Hours Life Tested
- ✓ CE Certified (EMC & LVD)
- ✓ IP Rated
- ✓ Rustproof
- ✓ UL94V0
- ✓ BS 5839 Part 8 & EN 60849
- ✓ EASE Data
- ✓ RoHS Compliance
- ✓ UV Stable
- ✓ Withstanding/Insulation Tested

Engineered to provide the highest quality voice and music reproduction for both indoor and outdoor applications where long throw, large area coverage is desired in harsh environments. Ideal for applications such as sports stadiums, cruise liners, school yards, municipal swimming pools, high ambient industrial areas and leisure / theme parks

- Compliant to British Standard BS 5839 part 8 and EN 60849
- Two cable entries to enable loop in loop out installation
- Available in 60 watt
- Ingress protected to IEC 60529 IP 66
- Two-way capabilities for security / monitoring applications
- UV stable for years of outdoor use
- Trunion extruded aluminium bracket with stainless mounting screws
- Finished in grey

| | |
|--------------------------|---|
| Model No. | MUH-6600VA |
| Rated Power (rms) | 60W |
| Impedance | 83Ω, 167Ω, 333Ω, 667kΩ & 1.33kΩ |
| Power Taps @ 100V | 60W, 30W, 15W & 7.5W |
| Power Taps @ 70V | 60W, 30W, 15W, 7.5W & 3.75W |
| SPL (1W / 1m) | 102dB |
| Max. SPL (Rated W / 1m) | 120dB |
| Frequency Range (-10dB) | 200 Hz ~ 20k Hz |
| Frequency Range (-20dB) | 110 Hz ~ 20k Hz |
| Dispersion 1k Hz / 4k Hz | 70° / 45° |
| Operating Temperature | -30°C ~ +70°C |
| Ingress Protection | IEC 60529 IP 66 |
| Power Selection | Ceramic terminal block |
| Material | Housing: UL94V0 high impact ABS with UV stable |
| Colour / Finish | Grey |
| Dimensions | 370.0 (14.57) X 255.0 (10.04) x 291.0 (11.46) Length mm (in.) |
| Net Weight (ea) | 5.42 kg (11.92 lb.) |
| Mounting | U Type aluminium bracket |