

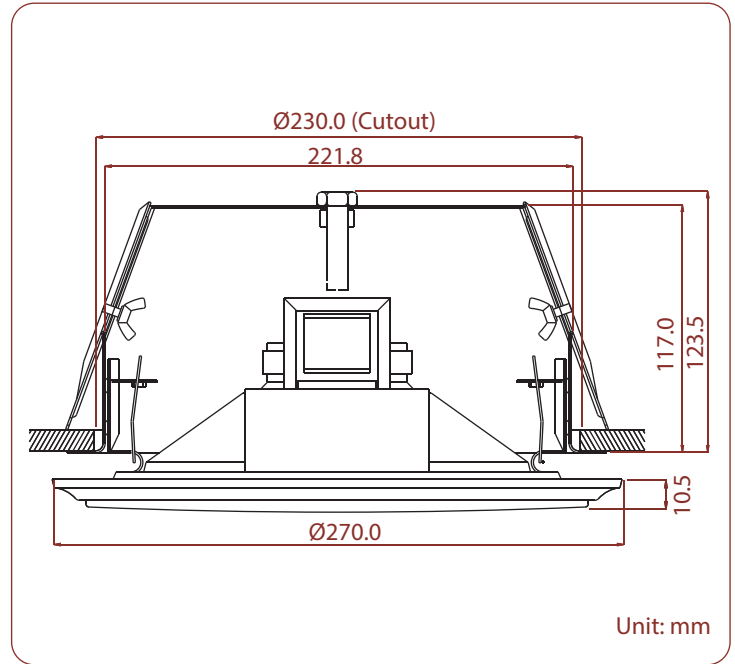

QCM-8200CVAF

Quick-Mount Ceiling Loudspeaker

【Voice Alarm】



- 100 Hours Life Tested
- CE Certified (EMC & LVD)
- IP Rated
- Rustproof
- UL94V0
- BS 5839 Part 8 & EN 60849
- EASE Data
- RoHS Compliance
- UV Stable
- Withstanding/Insulation Tested

- Compliant with British Standard BS 5839 part 8 and EN 60849
- Twin gland entry steel fire dome with patented "SUPER-FIT" system
- Mild steel construction capable of withstanding temperature of 650°C
- Ceramic termination blocks and fire resistant internal cabling
- 150°C thermal isolating fuse
- Excellent low frequency response
- Dished grille design for acoustic integrity
- Finished in white

Model No.	QCM-8200CVAF
Rated Power (rms)	20W
Impedance	250Ω, 500Ω, 1kΩ, 2kΩ & 4kΩ
Power Taps @ 100V	20W, 10W, 5W & 2.5W
Power Taps @ 70V	20W, 10W, 5W, 2.5W & 1.25W
SPL (1W / 1m)	92dB
Max. SPL (Rated W / 1m)	105dB
Frequency Range (-10dB)	70 Hz ~ 20k Hz
Dispersion 1k Hz / 4k Hz	100° / 50°
Operating Temperature	-30°C ~ +60°C
Power Selection	Plug
Material	Baffle: Steel, Grille: Steel
Colour / Finish	White
Dimensions	270.0 (10.63) Dia. X 134.0 (5.27) Height mm. (in.)
Cutout Size	230.0 (9.06) Dia. mm. (in.)
Net Weight (ea)	2.70 kg (5.94 lb.)
Mounting	Spring loaded Quick-Mount assembly